

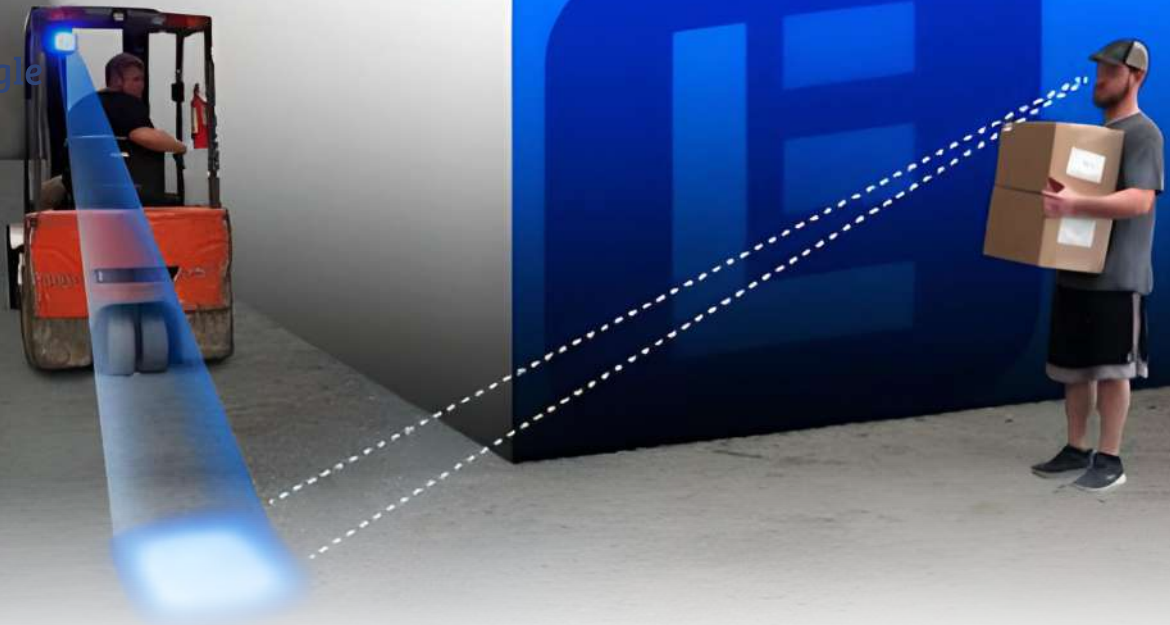

# Forklift Spot Safety Light

Model No. SE-01-010 SSL



## ▶ **Product Description:**

Sharpeagle's Blue Spot Light stands out as an excellent tool for alerting pedestrians and other vehicles as they approach blind corners of forklifts and exit semi-trailers. With a beam projection spot on the ground, the Blue Spot Light is 100% water, dust and quakeproof. It is enclosed in Casting Aluminum Alloy Housing, which is suitable for reducing heat.

## ▶ **Product Features:**

- Tempered glass cover.
- High Power LED with high quality.
- Beam: Projector spot on the ground.
- Ingress protection: IP-67
- Warranty: 1 year
- Double insulated silicon rubberized wire, which can bear very low & high temperature.
- Casting Aluminium Alloy housing, the suitable design for heating elimination.

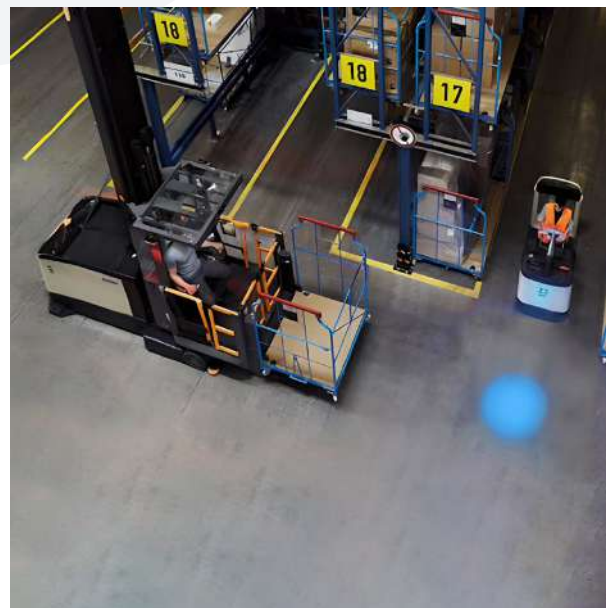

## Product Specifications:

(LED) High-power	Osram LED 1 pcs*3w
Lux	900lux on the ground @5m
Voltage	10~80V DC or 10-110V DC (Customized)
Color	Blue or Red
Life Time	30000 Hours
Working Temperature	-45°C ~ 85°C
Light Resource	HIGH POWER LED
Size	85*80*86mm

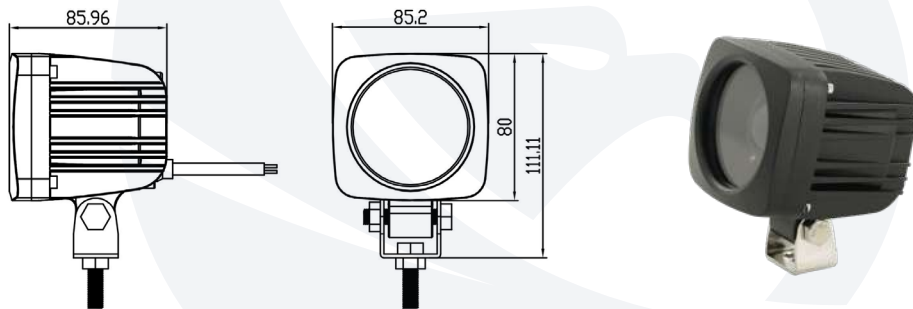

Scan for more details



Scan for video